



# POWERSPORTS BATTERY Maintenance-Free AGM Battery Series

## CTX19-BS 12V 19AH(10HR)



JIS  
D5302

### Specification

BATTERY TYPE NUMBER	VOLTAGE (V)	CAPACITY AH (10HR)	CCA @-18°C	MAXIMUM DIMENSIONS						WEIGHT			
				MILLIMETERS (±2 mm)			INCHES (±1/16 in)			BATTERY ONLY		INCLUDE ACID AND PACKAGE	
				L	W	H	L	W	H	Kg	Lbs	Kg	Lbs
CTX19-BS	12	19	260	175	101	157	6 7/8	3 15/16	6 3/16	5.65	12.44	8.85	19.49

### Dimension

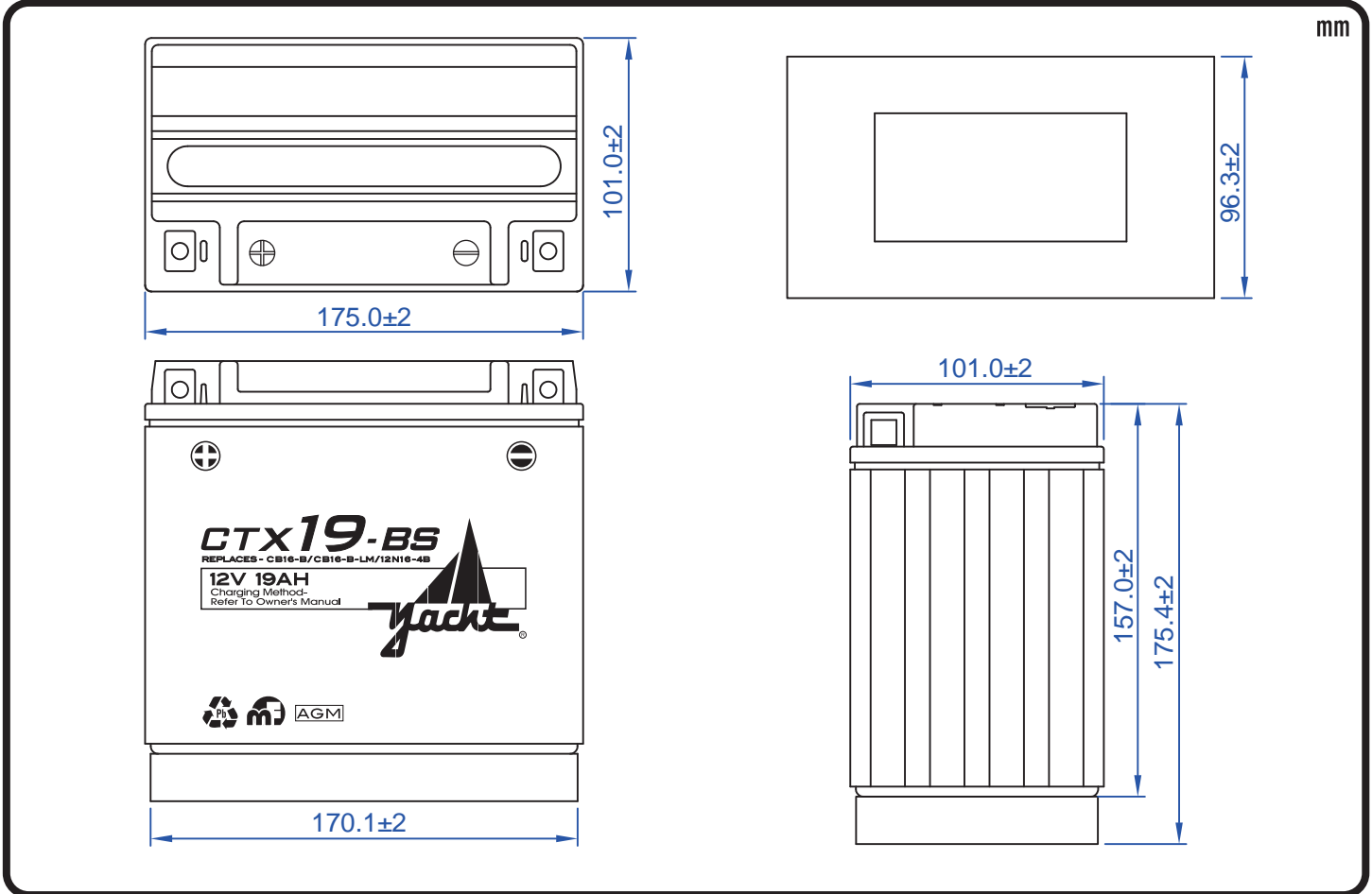

### Terminal Configuration

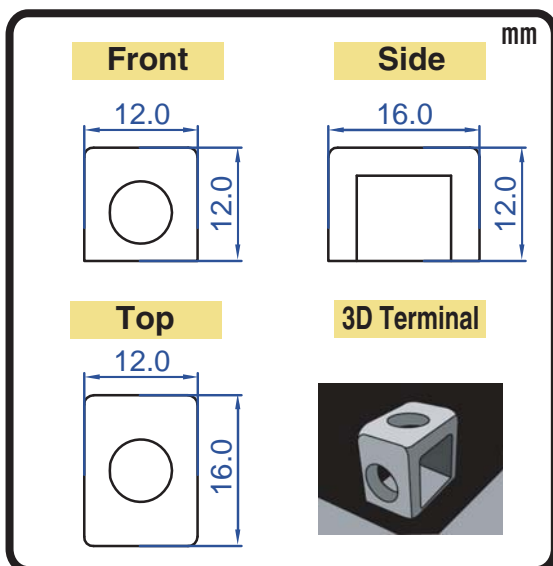

### Nut & Bolt Hardware Kits

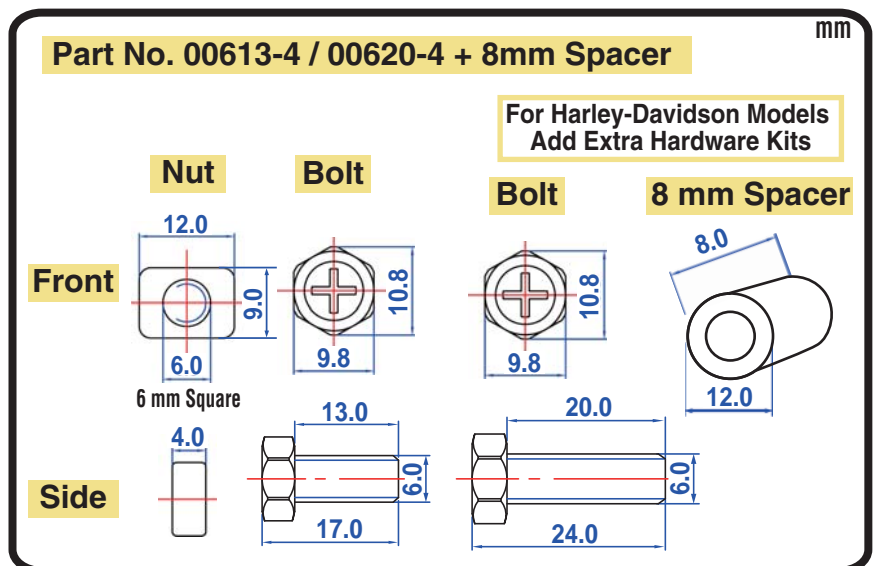

#### CORPORATE HEADQUARTERS (TAICHUNG, TAIWAN)

4F-5, No. 925, Sec. 4, Taiwan Blvd., Taichung, 40767 Taiwan, R.O.C.  
Tel : 886-4-2358-0578 Fax : 886-4-2358-0059  
sales@yacht-battery.com

#### YACHT BATTERY USA, INC.

Tel : 1-610-689-0443 Fax : 1-888-373-6466  
Dave.Beidler@yacht-battery.com  
Bruce.Ash@yacht-battery.com